

Breaker Interface Module (BIM)

Fail safe device for switching primary equipment

Breaker Interface Module (BIM)

Robust design for long life

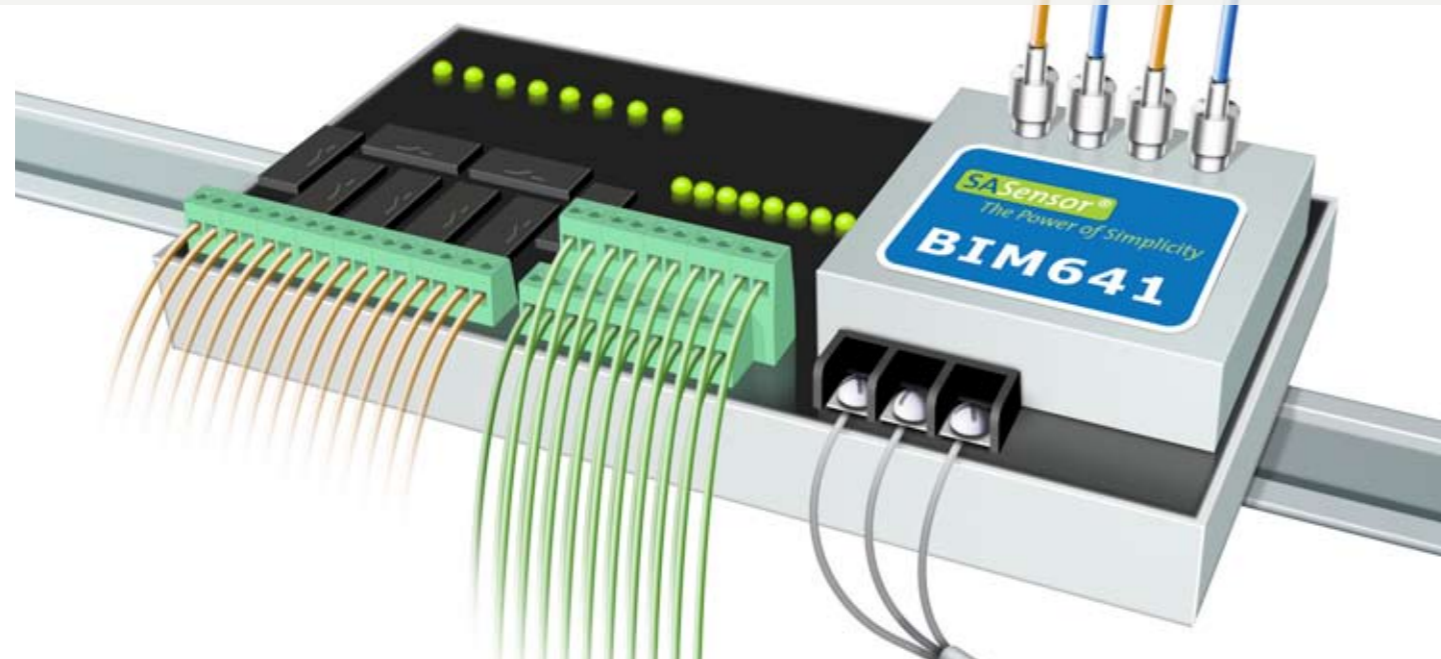

The Breaker Interface Module (BIM) is a compact input/output interface to operate and monitor switchgear.

Designed for optimized operational life

The BIM is robustly designed for a long life and is ready for future application functions. The overwhelming functional properties will not limit future functions executing in the computing devices. The installed base of interface modules can remain untouched even if new functions are required. This saves the cost and risks of primary outage, time consuming engineering and site installation work.

Heavy duty relay digital outputs

The BIM contains 8 relay outputs as single, normally open, heavy duty relay contacts. Each contact is provided two circuit supervision schemes; one monitors the circuit connected to the “to-be-closed” contact, the other monitors the ability of activating the output.

Protected against spurious operation

The output relays are designed to never close spontaneously and always operate on a control command. Internal error detection and reporting to the diagnostic software of the computing device. To avoid undesired operation of switchgear, the software in the computing devices sends two “select before execute” messages to active an output relay.

The BIM features:

- 10 digital inputs, supplying their own power to external dry contacts, such as position, indication and alarm contacts.
- 8 relay outputs as single, normally open, heavy duty relay contacts. Each contact is provided with two circuit supervision schemes; one to monitor

- the electrical circuit to where the “to-be-closed” contact is connected, the other to monitor the ability of activating the output.
- Power supply capable for wide input DC voltage range.
- Two duplex ports of 100Base FX Fast Ethernet with ST connectors for multi-mode fiber optic with separate strands for receive and transmit.

The BIM is designed for long life and maintenance free operation.

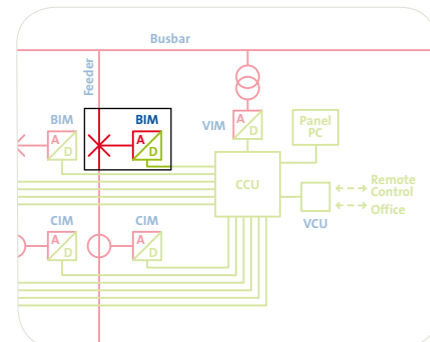

Breaker Interface Module (BIM)

Reliability in control

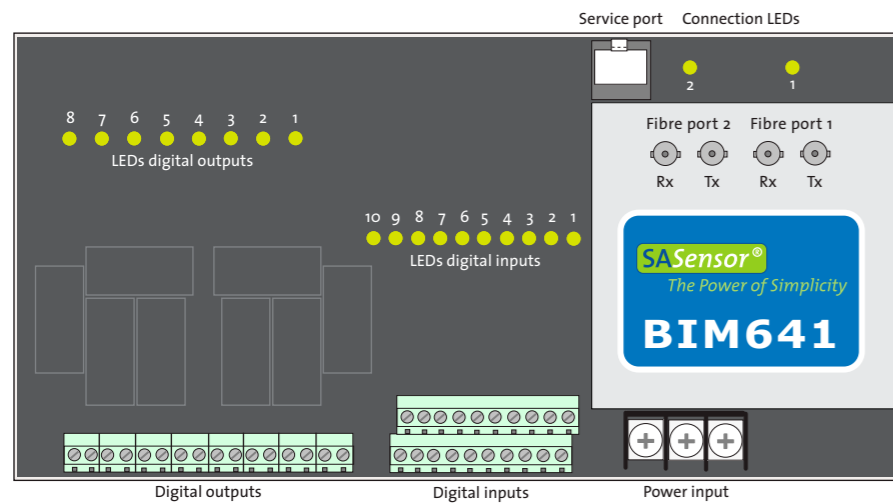

Connections

Digital input connection

The digital inputs are self-wetting. Therefore only potential free contact switches, such as position, indication and alarm contacts, should be connected to the inputs. The inputs are internally connected to the power supply of the BIM.

Digital output connection

The digital outputs are single pole heavy-duty relay outputs. Each relay has normally open contacts. The output terminal can be used in series or parallel in the free configurable software in the computing devices.

Fail Safe

Output relays should always work

The output relays are periodically checked to ensure that they will function correctly. If an internal error is detected this will be reported and the output is blocked.

Circuit supervision

The circuit supervision continuously monitors for output circuit interruption and high transition resistance caused by bad contacts or connections. When the supervision circuit detects a fault this is reported so that inspection or repair of the wiring or switchgear can be scheduled.

Data handling

The inputs of the BIM are time stamped with a high resolution. To prevent loss of data due to electromagnetic interference, the input data is transmitted repetitively and after every input event. Debounce filters on each input remove noise, glitches and spikes from external contacts.

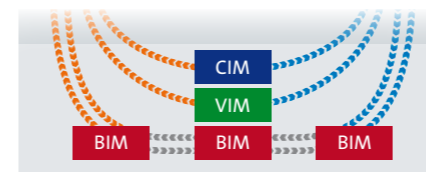

The BIMs can be connected in series



Digital input and output connectors

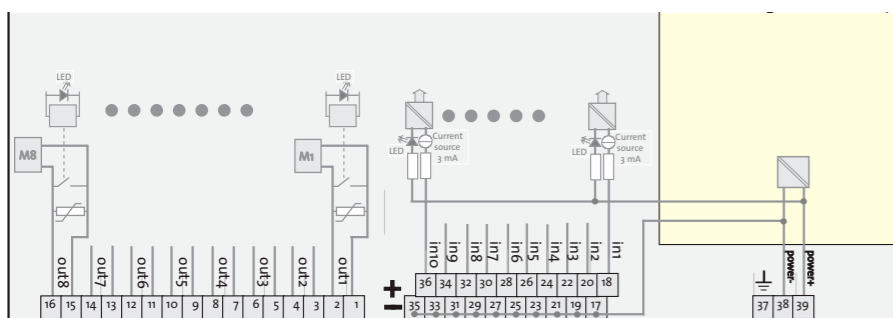

Digital inputs	
Number	10 self wetting with one common "zero"
Wetting switch. current	Typical 3 mA
Switching threshold (DC)	ON when load > 5 kΩ, OFF when load < 3,5 kΩ
Max. short-circuit	75 A @ 0.2 s

Digital outputs	
Number	8 relay outputs
Switching speed relay contact	Close: 15 ms (max) Open: 9 ms (typical)
Connectivity check current	1 mA (typical)
Max. switching voltage	300 Vdc, 300 Vac
Min. switching load	10 mA 5 Vdc
Max. inrush current	120 Vac, 78 A (TV-5)
Max. carrying current	6 A

Power supply input	
DC input range	38 V ... 275 V
Power consumption	7.1 W (min.), 10 W (typ.), 13.4 W (max.)
Fuse	5 AT

Mechanical	
Dimensions (L x W x H)	240 x 124 x 60 mm
Required height	110 mm
Weight	1.3 kg

Electromagnetic compatibility				
Test	Standard	Enclosure	PSU	DI/DO
Electrostatic discharge	IEC 61000-4-2	6 kV contact 8 kV air		
RF immunity radiated	IEC 61000-4-3	10 V/m		
Fast transient	IEC 61000-4-4	4 kV	4 kV	4 kV
Surge	IEC 61000-4-5		2 kV LE, 1 kV LL	4 kV LE
RF immunity conducted	IEC 61000-4-6	10 V	10 V	10 V
PF magnetic field	IEC 61000-4-7	100 A/m cont 1000 A/m for 1 s		
Dips	IEC 61000-4-11		0, 30, 60 %	
Interruptions	IEC 61000-4-11		100 %	
Variations	IEC 61000-4-11		+35 ... -20%	
100 kHz, 1 MHz oscillatory wave	IEC 61000-4-12 IEC 61000-4-18		2.5 kV CM 1.0 kV DM	2.5 kV CM 1.0 kV DM
Ripple	IEC 61000-4-17		12% Un	

Electromagnetic emission				
Test	Standard	Enclosure	PSU	VT IN
Radiated	IEC 61000-6-4 CISPR 22		Class A	
Conducted	IEC 61000-6-4 CISPR 22		Class A	

Climatic conditions				
Test	Standard	Enclosure	PSU	VT IN
Operating temperature	IEC 60068-2-1 IEC 60068-2-2		0 ... +55 °C	
Storage temperature	IEC 60068-2-1 IEC 60068-2-2		-10 ... +70 °C	
Humidity	IEC 60068-2-78		+40°C, 93% r.h., 10 days	

Mechanical conditions				
Test	Standard	Enclosure	PSU	VT IN
Vibration	IEC 60068-2-6		Class 1	
Shock	IEC 60068-2-31		Class 1	